

## WP 2-8 pellet stove



- 7,5 kW
- Built-in thermostat
- Programmable
- 21 kg pellet tank
- Extern Air
- Double walled construction
- 95% efficiency
- Flue connection rear: 80 mm
- H x W x D: 1060x490x500 mm
- For continuous use
- Fuel: pellet



Extern Air



Automat



Cleaning Air



Double casing



Continuous use

|                          |                                          |
|--------------------------|------------------------------------------|
| Certification            | 1.+2.Stufe 1.BImSchV , CE, 15aB-VG       |
| Heat output (kW)         | 7,5                                      |
| Min-max heat output (kW) | 2,5-7,5                                  |
| Heat capacity (m3)       | 375                                      |
| Flue gas quantity (g/s)  | 6,2                                      |
| Flue gas temperature (C) | 146                                      |
| Air needs Pa             | 6/11                                     |
| Size H x W x D (mm)      | 1060x490x500                             |
| Fuel                     | pellet (DIN 51731, DINplus, ÖNORM M7135) |
| Net weight (kg)          | 96                                       |

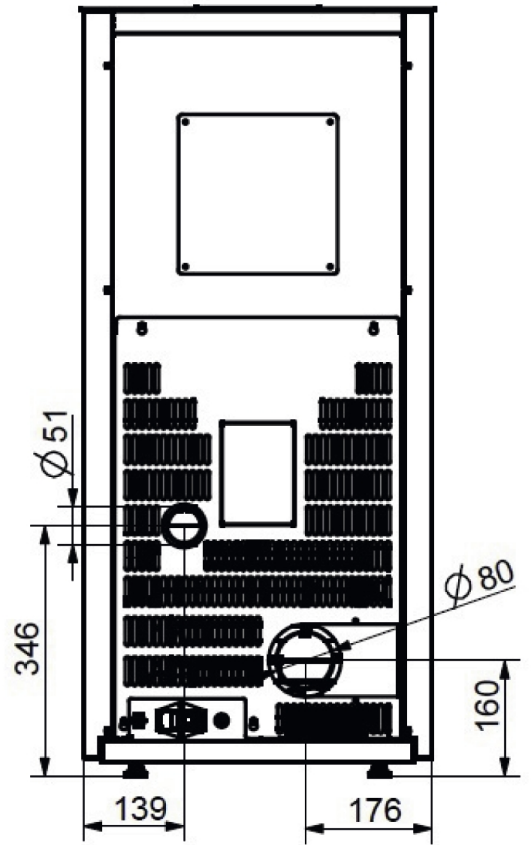
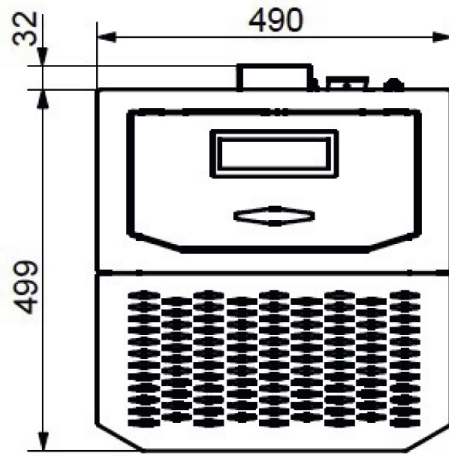
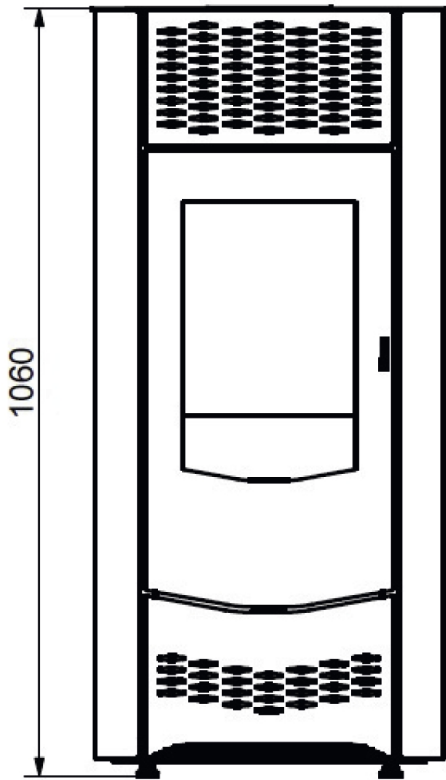

Wamsler SE  
3100 Salgótarján, Rákóczi út 53-55  
[www.wamsler.hu](http://www.wamsler.hu)